

AWK-1131A Series

Entry-level industrial IEEE 802.11a/b/g/n wireless AP/client



Features and Benefits

- IEEE 802.11a/b/g/n AP/client support
- Millisecond-level Client-based Turbo Roaming¹
- Integrated antenna and power isolation
- 5 GHz DFS channel support

Certifications



Introduction

The AWK-1131A industrial wireless AP/client meets the growing need for faster data transmission speeds by supporting IEEE 802.11n technology with a net data rate of up to 300 Mbps. The AWK-1131A is compliant with industrial standards and approvals covering operating temperature, power input voltage, surge, ESD, and vibration. The two redundant DC power inputs increase the reliability of the power supply. The AWK-1131A can operate on either the 2.4 or 5 GHz bands and is backwards-compatible with existing 802.11a/b/g deployments to future-proof your wireless investments.

Improved Higher Data Rate and Channel Capacity

- High-speed wireless connectivity with up to 300 Mbps data rate
- MIMO technology to improve the capability of transmitting and receiving multiple data streams
- Increased channel width with channel bonding technology
- Supports flexible channel selection to build up wireless communication system with DFS

Specifications for Industrial-grade Applications

- Redundant DC power inputs
- Integrated isolation design with enhanced protection against environmental interference
- Compact aluminum housing, IP30-rated

Specifications

WLAN Interface

WLAN Standards	802.11a/b/g/n 802.11i Wireless Security
Modulation Type	DSSS OFDM MIMO-OFDM
Frequency Band for US (20 MHz operating channels)	2.412 to 2.462 GHz (11 channels) 5.180 to 5.240 GHz (4 channels) 5.260 to 5.320 GHz (4 channels) ² 5.500 to 5.700 GHz (11 channels) ² 5.745 to 5.825 GHz (5 channels)
Frequency Band for EU (20 MHz operating channels)	2.412 to 2.472 GHz (13 channels) 5.180 to 5.240 GHz (4 channels)

1. The Turbo Roaming recovery time indicated herein is an average of test results documented, in optimized conditions, across APs configured with interference-free 20-MHz RF channels, WPA2-PSK security, and default Turbo Roaming parameters. The clients are configured with 3-channel roaming at 100 Kbps traffic load. Other conditions may also impact roaming performance. For more information about Turbo Roaming parameter settings, refer to the product manual.
2. DFS (Dynamic Frequency Selection) channel support: In AP mode, when a radar signal is detected, the device will automatically switch to another channel. However, according to regulations, after switching channels, a 60-second availability check period is required before starting the service.

	5.260 to 5.320 GHz (4 channels) ³ 5.500 to 5.700 GHz (11 channels) ³																								
Frequency Band for JP (20 MHz operating channels)	2.412 to 2.484 GHz (14 channels) 5.180 to 5.240 GHz (4 channels) 5.260 to 5.320 GHz (4 channels) ³ 5.500 to 5.700 GHz (11 channels) ³																								
Wireless Security	WEP encryption (64-bit and 128-bit) WPA/WPA2-Enterprise (IEEE 802.1X/RADIUS, TKIP, AES) WPA/WPA2-Personal																								
Transmission Rate	802.11b: 1 to 11 Mbps 802.11a/g: 6 to 54 Mbps 802.11n: 6.5 to 300 Mbps																								
Transmitter Power for 802.11a	23±1.5 dBm @ 6 to 24 Mbps 21±1.5 dBm @ 36 Mbps 20±1.5 dBm @ 48 Mbps 18±1.5 dBm @ 54 Mbps																								
Transmitter Power for 802.11n (5 GHz)	23±1.5 dBm @ MCS0/8 20 MHz 18±1.5 dBm @ MCS7/15 20 MHz 23±1.5 dBm @ MCS0/8 40 MHz 17±1.5 dBm @ MCS7/15 40 MHz																								
Transmitter Power for 802.11b	26±1.5 dBm @ 1 Mbps 26±1.5 dBm @ 2 Mbps 26±1.5 dBm @ 5.5 Mbps 25±1.5 dBm @ 11 Mbps																								
Transmitter Power for 802.11g	23±1.5 dBm @ 6 to 24 Mbps 21±1.5 dBm @ 36 Mbps 19±1.5 dBm @ 48 Mbps 18±1.5 dBm @ 54 Mbps																								
Transmitter Power for 802.11n (2.4 GHz)	23±1.5 dBm @ MCS0/8 20 MHz 18±1.5 dBm @ MCS7/15 20 MHz 23±1.5 dBm @ MCS0/8 40 MHz 17±1.5 dBm @ MCS7/15 40 MHz																								
Transmitter Power	<table border="1"> <thead> <tr> <th></th> <th>US</th> <th>EU</th> <th>JP</th> </tr> </thead> <tbody> <tr> <td>2.4 GHz</td> <td>26 dBm</td> <td>18 dBm</td> <td>18 dBm</td> </tr> <tr> <td>5 GHz (UNII-1)</td> <td>23 dBm</td> <td>21 dBm</td> <td>21 dBm</td> </tr> <tr> <td>5 GHz (UNII-2)</td> <td>23 dBm</td> <td>21 dBm</td> <td>21 dBm</td> </tr> <tr> <td>5 GHz (UNII-2e)</td> <td>23 dBm</td> <td>23 dBm</td> <td>23 dBm</td> </tr> <tr> <td>5 GHz (UNII-3)</td> <td>23 dBm</td> <td>–</td> <td>–</td> </tr> </tbody> </table> <p>Note: Based on regional regulations, the maximum transmission power allowed on the UNII bands is restricted in the firmware, as indicated above.</p>		US	EU	JP	2.4 GHz	26 dBm	18 dBm	18 dBm	5 GHz (UNII-1)	23 dBm	21 dBm	21 dBm	5 GHz (UNII-2)	23 dBm	21 dBm	21 dBm	5 GHz (UNII-2e)	23 dBm	23 dBm	23 dBm	5 GHz (UNII-3)	23 dBm	–	–
	US	EU	JP																						
2.4 GHz	26 dBm	18 dBm	18 dBm																						
5 GHz (UNII-1)	23 dBm	21 dBm	21 dBm																						
5 GHz (UNII-2)	23 dBm	21 dBm	21 dBm																						
5 GHz (UNII-2e)	23 dBm	23 dBm	23 dBm																						
5 GHz (UNII-3)	23 dBm	–	–																						
Receiver Sensitivity for 802.11a (measured at 5.680 GHz)	Typ. -90 @ 6 Mbps Typ. -88 @ 9 Mbps Typ. -88 @ 12 Mbps Typ. -85 @ 18 Mbps Typ. -81 @ 24 Mbps Typ. -78 @ 36 Mbps Typ. -74 @ 48 Mbps Typ. -72 @ 54 Mbps Note ⁴																								
Receiver Sensitivity for 802.11n (5 GHz; measured at 5.680 GHz)	Typ. -69 dBm @ MCS7 20 MHz Typ. -71 dBm @ MCS15 20 MHz																								

- DFS (Dynamic Frequency Selection) channel support: In AP mode, when a radar signal is detected, the device will automatically switch to another channel. However, according to regulations, after switching channels, a 60-second availability check period is required before starting the service.
- Due to a limitation in the receiver sensitivity performance for channels 153 and 161, it is recommended to avoid using these channels in your critical applications.

	Typ. -63 dBm @ MCS7 40 MHz Typ. -68 dBm @ MCS15 40 MHz Note ⁵
Receiver Sensitivity for 802.11b (measured at 2.437 GHz)	Typ. -93 dBm @ 1 Mbps Typ. -93 dBm @ 2 Mbps Typ. -93 dBm @ 5.5 Mbps Typ. -88 dBm @ 11 Mbps
Receiver Sensitivity for 802.11g (measured at 2.437 GHz)	Typ. -88 dBm @ 6 Mbps Typ. -86 dBm @ 9 Mbps Typ. -85 dBm @ 12 Mbps Typ. -85 dBm @ 18 Mbps Typ. -85 dBm @ 24 Mbps Typ. -82 dBm @ 36 Mbps Typ. -78 dBm @ 48 Mbps Typ. -74 dBm @ 54 Mbps
Receiver Sensitivity for 802.11n (2.4 GHz; measured at 2.437 GHz)	Typ. -70 dBm @ MCS7 20 MHz Typ. -69 dBm @ MCS15 20 MHz Typ. -67 dBm @ MCS7 40 MHz Typ. -67 dBm @ MCS15 40 MHz
WLAN Operation Mode	Access point, Client, Sniffer
Antenna	External, 2/2 dBi, Omni-directional
Antenna Connectors	2 RP-SMA female
Ethernet Interface	
Standards	IEEE 802.3 for 10BaseT IEEE 802.3u for 100BaseT(X) IEEE 802.3ab for 1000BaseT(X) IEEE 802.1X for authentication
10/100/1000BaseT(X) Ports (RJ45 connector)	1
Ethernet Software Features	
Management	DHCP Server/Client, DNS, HTTP, IPv4, LLDP, Proxy ARP, SMTP, SNMPv1/v2c/v3, Syslog, TCP/IP, Telnet, UDP, VLAN, Wireless Search Utility, MXview, MXconfig
Security	HTTPS/SSL, RADIUS, SSH
Time Management	SNTP Client
Firewall	
Filter	ICMP, MAC address, IP protocol, Port-based
Serial Interface	
Console Port	RS-232, 8-pin RJ45
LED Interface	
LED Indicators	PWR, FAULT, STATE, SIGNAL, WLAN, LAN
Input/Output Interface	
Buttons	Reset button
Physical Characteristics	
Housing	Metal
IP Rating	IP30

5. Due to a limitation in the receiver sensitivity performance for channels 153 and 161, it is recommended to avoid using these channels in your critical applications.

Dimensions	58 x 115 x 70 mm (2.29 x 4.53 x 2.76 in)
Weight	307 g (0.68 lb)
Installation	DIN-rail mounting, Wall mounting (with optional kit)
Power Parameters	
Input Current	0.56 A @ 12 VDC, 0.14 A @ 48 VDC
Input Voltage	12 to 48 VDC
Power Connector	1 removable 4-contact terminal block(s)
Power Consumption	6.96 W (max.)
Reverse Polarity Protection	Supported
Environmental Limits	
Operating Temperature	Standard Models: 0 to 60°C (32 to 140°F) Wide Temp. Models: -40 to 75°C (-40 to 167°F)
Storage Temperature (package included)	-40 to 85°C (-40 to 185°F)
Ambient Relative Humidity	5 to 95% (non-condensing)
Standards and Certifications	
EMC	EN 55032/24
EMI	CISPR 32, FCC Part 15B Class B
EMS	IEC 61000-4-2 ESD: Contact: 4 kV; Air: 8 kV IEC 61000-4-3 RS: 80 MHz to 1 GHz: 10 V/m IEC 61000-4-4 EFT: Power: 2 kV; Signal: 1 kV IEC 61000-4-5 Surge: Power: 2 kV; Signal: 1 kV IEC 61000-4-6 CS: 3 V IEC 61000-4-8 PFMF
Radio	EN 300 328, EN 301 489-1/17, EN 301 893, FCC ID SLE-WAPN008, ANATEL, MIC, NCC, RCM, SRRC, WPC, KC, RCM
Safety	EN 60950-1, UL 60950-1
Vibration	IEC 60068-2-6
MTBF	
Time	749,476 hrs
Standards	Telcordia SR332
Warranty	
Warranty Period	5 years
Details	See www.moxa.com/warranty
Package Contents	
Device	1 x AWK-1131 Series wireless AP/client
Installation Kit	1 x cap, plastic, for RJ45 port 1 x DIN-rail kit
Antenna	2 x 2.4/5 GHz antenna
Documentation	1 x quick installation guide 1 x warranty card

Dimensions

Unit: mm (inch)

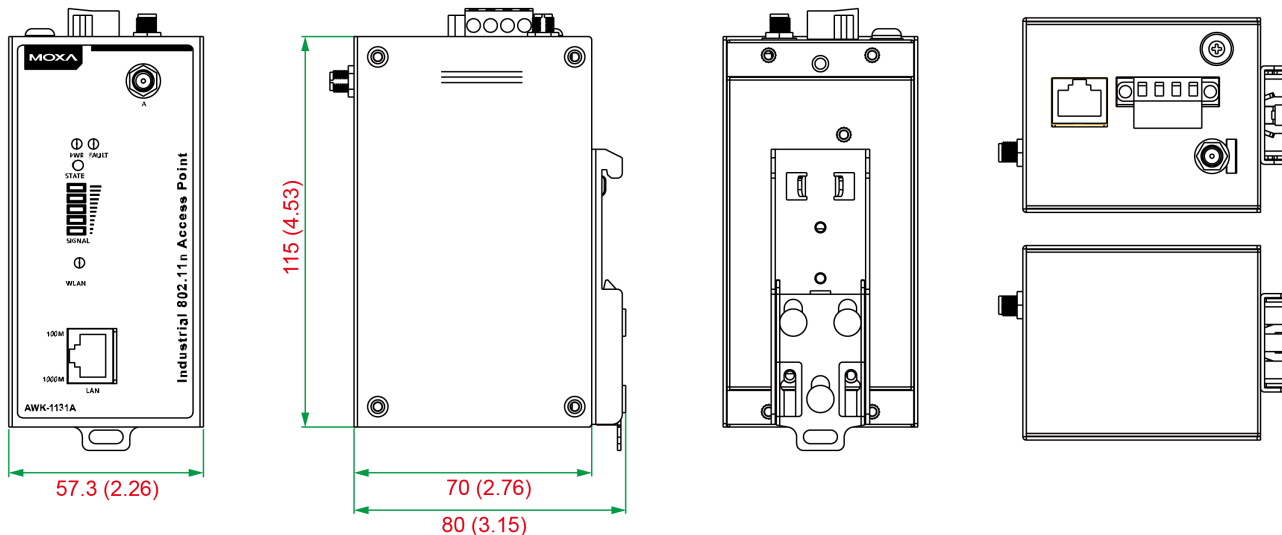

Front View

Side View

Rear View

Top and Bottom Views

Ordering Information

Model Name	Band	Standards	Operating Temp.
AWK-1131A-EU	EU	802.11a/b/g/n	0 to 60°C
AWK-1131A-EU-T	EU	802.11a/b/g/n	-40 to 75°C
AWK-1131A-JP	JP	802.11a/b/g/n	0 to 60°C
AWK-1131A-JP-T	JP	802.11a/b/g/n	-40 to 75°C
AWK-1131A-US	US	802.11a/b/g/n	0 to 60°C
AWK-1131A-US-T	US	802.11a/b/g/n	-40 to 75°C

Accessories (sold separately)

Antennas

ANT-WDB-ANF-0407	2.4/5 GHz, omni-directional antenna, 4/7 dBi, N-type (male)
ANT-WDB-ANF-0609	2.4/5 GHz, omni-directional antenna, 6/9 dBi, N-type (female)
ANT-WDB-ANM-0306	2.4/5 GHz, omni-directional antenna, 3/6 dBi, N-type (male)
ANT-WDB-ANM-0407	2.4/5 GHz, dual-band omni-directional antenna, 4/7 dBi, N-type (male)
ANT-WDB-ANM-0502	2.4/5 GHz, omni-directional antenna, 5/2 dBi, N-type (male)
ANT-WDB-ANM-0609	2.4/5 GHz, omni-directional antenna, 6/9 dBi, N-type (male)
ANT-WDB-ARM-02	2.4/5 GHz, omni-directional rubber duck antenna, 2 dBi, RP-SMA (male)
ANT-WDB-ARM-0202	2.4/5 GHz, panel antenna, 2/2 dBi, RP-SMA (male)
ANT-WDB-PNF-1518	2.4/5 GHz, panel antenna, 15/18 dBi, N-type (female)
MAT-WDB-CA-RM-2-0205	2.4/5 GHz, ceiling antenna, 2/5 dBi, MIMO 2x2, RP-SMA-type (male)
MAT-WDB-DA-RM-2-0203-1m	2.4/5 GHz, desktop antenna, 2/3 dBi, MIMO 2x2, RP-SMA-type (male), 1 m cable
MAT-WDB-PA-NF-2-0708	2.4/5 GHz, panel antenna, 7/8 dBi, MIMO 2x2, N-type (female)
ANT-WSB5-ANF-12	5 GHz, omni-directional antenna, 12 dBi, N-type (female)
ANT-WSB5-PNF-18	5 GHz, directional panel antenna, 18 dBi, N-type (female)
ANT-WSB-ANF-09	2.4 GHz, omni-directional antenna, 9 dBi, N-type (female)

ANT-WSB-PNF-12	2.4 GHz, directional panel antenna, 12dBi, N-type (female)
ANT-WSB-PNF-18	2.4 GHz, directional panel antenna, 18 dBi, N-type (female)
ANT-WSB-AHRM-05-1.5m	2.4 GHz, omni-directional/dipole antenna, 5 dBi, RP-SMA (male), 1.5 m cable

Wireless Antenna Cables

A-CRF-RFRM-R4-150	RF magnetic stand, RP-SMA (male) to RP-SMA (female), RG-174/U cable, 1.5 m
A-CRF-RMNM-L1-300	N-type (male) to RP SMA (male), LMR-195 Lite cable, 3 m
A-CRF-RMNM-L1-600	N-type (male) to RP SMA (male), LMR-195 Lite cable, 6 m
A-CRF-RMNM-L1-900	N-type (male) to RP SMA (male), LMR-195 Lite cable, 9 m
CRF-N0117SA-3M	N-type (male) to RP SMA (male), CFD200 cable, 3 m
A-CRF-RFRM-S2-60	SS402 cable, RP-SMA (male) to RP-SMA (female)

Surge Arrestors

A-SA-NFNF-01	Surge arrester, N-type (female) to N-type (female)
A-SA-NMNF-01	Surge arrester, N-type (female) to N-type (male)

Wireless Adapters

A-ADP-RJ458P-DB9F-ABC01	DB9 female to RJ45 connector for the ABC-01
-------------------------	---

Wireless Terminating Resistors

A-TRM-50-RM	Termination resistor, 50 ohms, N-type male
-------------	--

Wall-Mounting Kits

WK-51-01	Wall-mounting kit, 2 plates, 6 screws, 51.6 x 67 x 2 mm
----------	---

© Moxa Inc. All rights reserved. Updated Sep 05, 2019.

This document and any portion thereof may not be reproduced or used in any manner whatsoever without the express written permission of Moxa Inc. Product specifications subject to change without notice. Visit our website for the most up-to-date product information.

AWK-1137C Series

Industrial 802.11a/b/g/n wireless client



Features and Benefits

- IEEE 802.11a/b/g/n compliant client
- Comprehensive interfaces with one serial port and two Ethernet LAN ports
- Millisecond-level Client-based Turbo Roaming¹
- Easy setup and deployment with AeroMag
- 2x2 MIMO future-proof technology
- Easy network setup with Network Address Translation (NAT)
- Integrated robust antenna and power isolation
- Anti-vibration design
- Compact size for your industrial applications

Certifications



Introduction

The AWK-1137C is an ideal client solution for industrial wireless mobile applications. It enables WLAN connections for both Ethernet and serial devices, and is compliant with industrial standards and approvals covering operating temperature, power input voltage, surge, ESD, and vibration. The AWK-1137C can operate on either the 2.4 or 5 GHz bands, and is backwards-compatible with existing 802.11a/b/g deployments to future-proof your wireless investments.

Industrial Ruggedness

- Integrated antenna and power isolation designed to provide 500 V insulation protection against external electrical interference
- -40 to 75°C wide operating temperature models (-T) available for smooth wireless communication in harsh environments

Mobility-oriented Design

- Client-based Turbo Roaming¹ for < 150 ms roaming recovery time between APs
- MIMO technology to ensure transmitting and receiving capability while on the move
- Anti-vibration performance (with reference to IEC 60068-2-6)

Easy Integration

- Semi-automatically configurable to reduce deployment cost
- AeroMag support for error-free setup of your industrial applications' basic WLAN settings
- Various communication interfaces for connecting to different types of devices
- One-to-many NAT to simplify your machine setup

Specifications

WLAN Interface

WLAN Standards	802.11a/b/g/n 802.11i Wireless Security
Modulation Type	DSSS OFDM MIMO-OFDM
Frequency Band for US (20 MHz operating channels)	2.412 to 2.462 GHz (11 channels) 5.180 to 5.240 GHz (4 channels)

1. The Turbo Roaming recovery time indicated herein is an average of test results documented, in optimized conditions, across APs configured with interference-free 20-MHz RF channels, WPA2-PSK security, and default Turbo Roaming parameters. The clients are configured with 3-channel roaming at 100 Kbps traffic load. Other conditions may also impact roaming performance. For more information about Turbo Roaming parameter settings, refer to the product manual.

	5.260 to 5.320 GHz (4 channels) ² 5.500 to 5.700 GHz (11 channels) ² 5.745 to 5.825 GHz (5 channels)																								
Frequency Band for EU (20 MHz operating channels)	2.412 to 2.472 GHz (13 channels) 5.180 to 5.240 GHz (4 channels) 5.260 to 5.320 GHz (4 channels) ² 5.500 to 5.700 GHz (11 channels) ²																								
Frequency Band for JP (20 MHz operating channels)	2.412 to 2.484 GHz (14 channels) 5.180 to 5.240 GHz (4 channels) 5.260 to 5.320 GHz (4 channels) ² 5.500 to 5.700 GHz (11 channels) ²																								
Wireless Security	WEP encryption (64-bit and 128-bit) WPA/WPA2-Enterprise (IEEE 802.1X/RADIUS, TKIP, AES) WPA/WPA2-Personal																								
Transmission Rate	802.11b: 1 to 11 Mbps 802.11a/g: 6 to 54 Mbps 802.11n: 6.5 to 300 Mbps																								
Transmitter Power for 802.11a	23±1.5 dBm @ 6 to 24 Mbps 21±1.5 dBm @ 36 Mbps 20±1.5 dBm @ 48 Mbps 18±1.5 dBm @ 54 Mbps																								
Transmitter Power for 802.11n (5 GHz)	23±1.5 dBm @ MCS0/8 20 MHz 18±1.5 dBm @ MCS7/15 20 MHz 23±1.5 dBm @ MCS0/8 40 MHz 18±1.5 dBm @ MCS7/15 40 MHz																								
Transmitter Power for 802.11b	26±1.5 dBm @ 1 Mbps 26±1.5 dBm @ 2 Mbps 26±1.5 dBm @ 5.5 Mbps 25±1.5 dBm @ 11 Mbps																								
Transmitter Power for 802.11g	23±1.5 dBm @ 6 to 24 Mbps 22±1.5 dBm @ 36 Mbps 20±1.5 dBm @ 48 Mbps 19±1.5 dBm @ 54 Mbps																								
Transmitter Power for 802.11n (2.4 GHz)	23±1.5 dBm @ MCS0/8 20 MHz 17±1.5 dBm @ MCS7/15 20 MHz 23±1.5 dBm @ MCS0/8 40 MHz 17±1.5 dBm @ MCS7/15 40 MHz																								
Transmitter Power	<table border="1"> <thead> <tr> <th></th> <th>US</th> <th>EU</th> <th>JP</th> </tr> </thead> <tbody> <tr> <td>2.4 GHz</td> <td>26 dBm</td> <td>18 dBm</td> <td>18 dBm</td> </tr> <tr> <td>5 GHz (UNII-1)</td> <td>23 dBm</td> <td>23 dBm</td> <td>23 dBm</td> </tr> <tr> <td>5 GHz (UNII-2)</td> <td>23 dBm</td> <td>23 dBm</td> <td>23 dBm</td> </tr> <tr> <td>5 GHz (UNII-2e)</td> <td>23 dBm</td> <td>23 dBm</td> <td>23 dBm</td> </tr> <tr> <td>5 GHz (UNII-3)</td> <td>23 dBm</td> <td>-</td> <td>-</td> </tr> </tbody> </table> <p>Note: Based on regional regulations, the maximum transmission power allowed on the UNII bands is restricted in the firmware, as indicated above.</p>		US	EU	JP	2.4 GHz	26 dBm	18 dBm	18 dBm	5 GHz (UNII-1)	23 dBm	23 dBm	23 dBm	5 GHz (UNII-2)	23 dBm	23 dBm	23 dBm	5 GHz (UNII-2e)	23 dBm	23 dBm	23 dBm	5 GHz (UNII-3)	23 dBm	-	-
	US	EU	JP																						
2.4 GHz	26 dBm	18 dBm	18 dBm																						
5 GHz (UNII-1)	23 dBm	23 dBm	23 dBm																						
5 GHz (UNII-2)	23 dBm	23 dBm	23 dBm																						
5 GHz (UNII-2e)	23 dBm	23 dBm	23 dBm																						
5 GHz (UNII-3)	23 dBm	-	-																						
Receiver Sensitivity for 802.11a (measured at 5.680 GHz)	Typ. -90 @ 6 Mbps Typ. -88 @ 9 Mbps Typ. -87 @ 12 Mbps Typ. -85 @ 18 Mbps Typ. -81 @ 24 Mbps Typ. -78 @ 36 Mbps																								

2. DFS (Dynamic Frequency Selection) channel support: In AP mode, when a radar signal is detected, the device will automatically switch to another channel. However, according to regulations, after switching channels, a 60-second availability check period is required before starting the service.

	Typ. -74 @ 48 Mbps Typ. -73 @ 54 Mbps Note ³
Receiver Sensitivity for 802.11n (5 GHz; measured at 5.680 GHz)	Typ. -69 dBm @ MCS7 20 MHz Typ. -70 dBm @ MCS15 20 MHz Typ. -64 dBm @ MCS7 40 MHz Typ. -66 dBm @ MCS15 40 MHz Note ³
Receiver Sensitivity for 802.11b (measured at 2.437 GHz)	Typ. -89 dBm @ 1 Mbps Typ. -89 dBm @ 2 Mbps Typ. -89 dBm @ 5.5 Mbps Typ. -88 dBm @ 11 Mbps
Receiver Sensitivity for 802.11g (measured at 2.437 GHz)	Typ. -88 dBm @ 6 Mbps Typ. -88 dBm @ 9 Mbps Typ. -88 dBm @ 12 Mbps Typ. -87 dBm @ 18 Mbps Typ. -84 dBm @ 24 Mbps Typ. -81 dBm @ 36 Mbps Typ. -77 dBm @ 48 Mbps Typ. -75 dBm @ 54 Mbps
Receiver Sensitivity for 802.11n (2.4 GHz; measured at 2.437 GHz)	Typ. -70 dBm @ MCS7 20 MHz Typ. -70 dBm @ MCS15 20 MHz Typ. -64 dBm @ MCS7 40 MHz Typ. -65 dBm @ MCS15 40 MHz
WLAN Operation Mode	Client, Client-Router, Slave, Sniffer
Antenna	External, 2/2 dBi, Omni-directional
Antenna Connectors	2 RP-SMA female
Ethernet Interface	
10/100BaseT(X) Ports (RJ45 connector)	2
Standards	IEEE 802.3 for 10BaseT IEEE 802.3u for 100BaseT(X) IEEE 802.1Q for VLAN Tagging
Ethernet Software Features	
Management	DHCP Server/Client, HTTP, IPv4, LLDP, SMTP, SNMPv1/v2c/v3, Syslog, TCP/IP, Telnet, UDP, Proxy ARP, VLAN, Wireless Search Utility, MXview, MXconfig
Routing	Port forwarding, Static Route, NAT
Security	HTTPS/SSL, RADIUS, SSH
Time Management	NTP Client, SNTP Client
Firewall	
Filter	ICMP, MAC address, IP protocol, Port-based
Serial Interface	
Connector	DB9 male
Serial Standards	RS-232, RS-422/485, RS-232/422/485
Operation Modes	Disabled, Real COM, RFC2217, TCP Client, TCP Server, UDP
Data Bits	5, 6, 7, 8
Stop Bits	1, 1.5, 2

3. Due to a limitation in the receiver sensitivity performance for channels 153 and 161, it is recommended to avoid using these channels in your critical applications.

Parity	None, Even, Odd, Space, Mark
Flow Control	None, RTS/CTS, XON/XOFF
Baudrate	75 bps to 921.6 kbps
Serial Data Log	256 KB

Serial Signals

RS-232	TxD, RxD, RTS, CTS, DCD, GND, DTR, DSR
RS-422	Tx+, Tx-, Rx+, Rx-, GND
RS-485-2w	Data+, Data-, GND
RS-485-4w	Tx+, Tx-, Rx+, Rx-, GND

LED Interface

LED Indicators	SYS, LAN1, LAN2, WLAN, Serial
----------------	-------------------------------

Input/Output Interface

Buttons	Reset button
---------	--------------

Physical Characteristics

Housing	Metal
IP Rating	IP30
Dimensions	77.1 x 115.5 x 26 mm (3.04 x 4.55 x 1.02 in)
Weight	470 g (1.03 lb)
Installation	DIN-rail mounting, Wall mounting (with optional kit)

Power Parameters

Input Voltage	9 to 30 VDC
Power Connector	1 removable 3-contact terminal block(s)
Power Consumption	11.7 W (max.)
Reverse Polarity Protection	Supported

Environmental Limits

Operating Temperature	Standard Models: 0 to 60°C (32 to 140°F) Wide Temp. Models: -40 to 75°C (-40 to 167°F)
Storage Temperature (package included)	-40 to 85°C (-40 to 185°F)
Ambient Relative Humidity	5 to 95% (non-condensing)

Standards and Certifications

EMC	EN 61000-6-2/-6-4, EN 55032/24
EMI	CISPR 22, FCC Part 15B Class A
EMS	IEC 61000-4-2 ESD: Contact: 8 kV; Air: 15 kV IEC 61000-4-3 RS: 80 MHz to 1 GHz: 10 V/m IEC 61000-4-4 EFT: Power: 2 kV; Signal: 1 kV IEC 61000-4-5 Surge: Power: 2 kV; Signal: 1 kV IEC 61000-4-6 CS: 10 V IEC 61000-4-8 PFMF

Radio	EN 300 328, EN 301 489-1/17, EN 301 893, FCC ID SLE-1137C, ANATEL, MIC, NCC, SRRC, WPC, KC, RCM
Road Vehicles	E mark E1
Safety	EN 60950-1, UL 60950-1
Vibration	IEC 60068-2-6

MTBF

Time	1,125,942 hrs
Standards	Telcordia SR332

Warranty

Warranty Period	5 years
Details	See www.moxa.com/warranty

Package Contents

Device	1 x AWK-1137C Series wireless client
Installation Kit	1 x DIN-rail kit
Antenna	2 x 2.4/5 GHz antenna
Documentation	1 x quick installation guide 1 x warranty card

Dimensions

Unit: mm (inch)

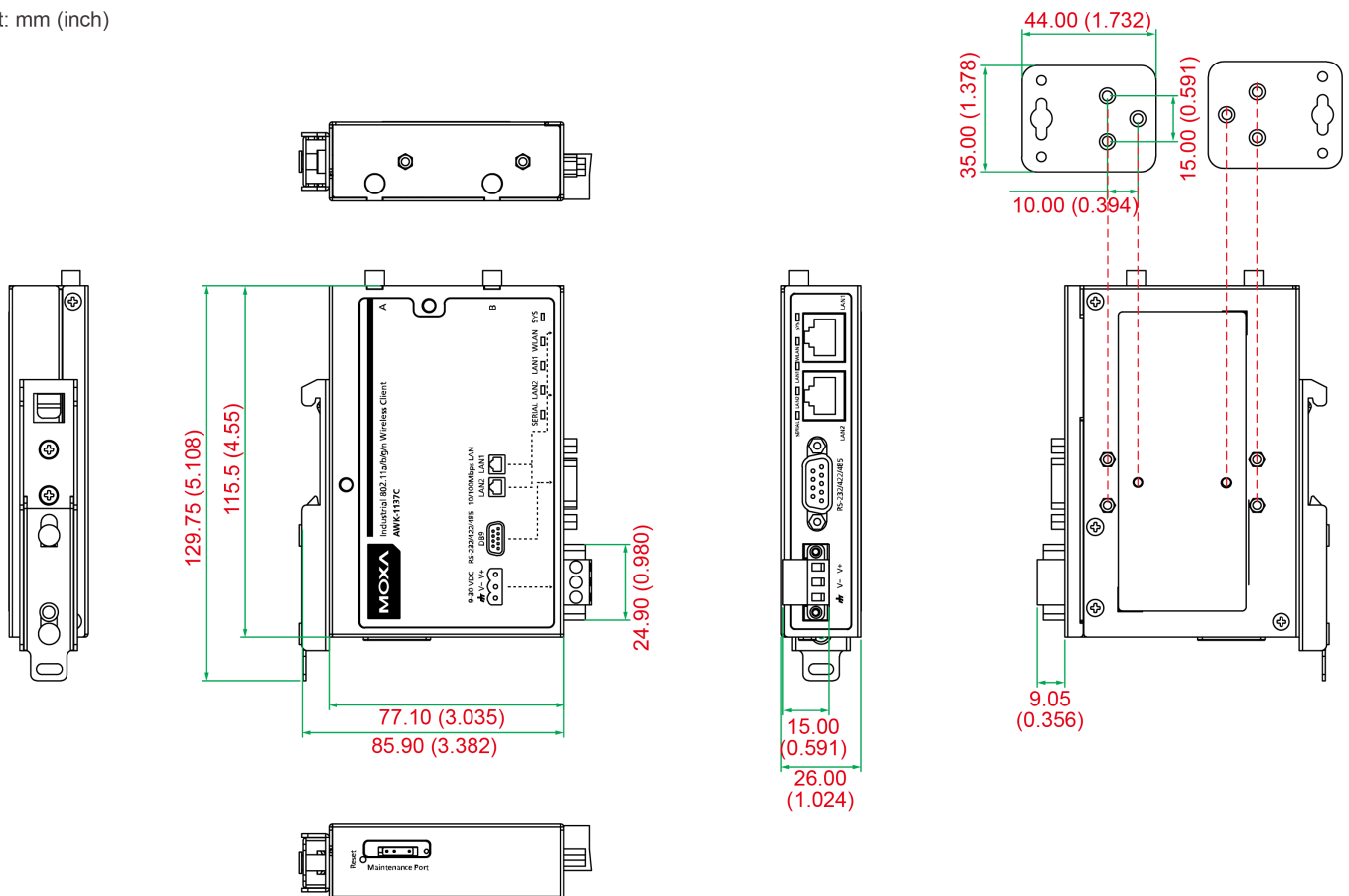

Ordering Information

Model Name	Band	Standards	Operating Temp.
AWK-1137C-EU	EU	802.11a/b/g/n	0 to 60°C
AWK-1137C-EU-T	EU	802.11a/b/g/n	-40 to 75°C
AWK-1137C-JP	JP	802.11a/b/g/n	0 to 60°C
AWK-1137C-JP-T	JP	802.11a/b/g/n	-40 to 75°C
AWK-1137C-US	US	802.11a/b/g/n	0 to 60°C
AWK-1137C-US-T	US	802.11a/b/g/n	-40 to 75°C

Accessories (sold separately)

Antennas

ANT-WDB-ANF-0407	2.4/5 GHz, omni-directional antenna, 4/7 dBi, N-type (male)
ANT-WDB-ANF-0609	2.4/5 GHz, omni-directional antenna, 6/9 dBi, N-type (female)
ANT-WDB-ANM-0306	2.4/5 GHz, omni-directional antenna, 3/6 dBi, N-type (male)
ANT-WDB-ANM-0407	2.4/5 GHz, dual-band omni-directional antenna, 4/7 dBi, N-type (male)
ANT-WDB-ANM-0502	2.4/5 GHz, omni-directional antenna, 5/2 dBi, N-type (male)
ANT-WDB-ANM-0609	2.4/5 GHz, omni-directional antenna, 6/9 dBi, N-type (male)
ANT-WDB-ARM-02	2.4/5 GHz, omni-directional rubber duck antenna, 2 dBi, RP-SMA (male)
ANT-WDB-ARM-0202	2.4/5 GHz, panel antenna, 2/2 dBi, RP-SMA (male)
ANT-WDB-PNF-1518	2.4/5 GHz, panel antenna, 15/18 dBi, N-type (female)
MAT-WDB-CA-RM-2-0205	2.4/5 GHz, ceiling antenna, 2/5 dBi, MIMO 2x2, RP-SMA-type (male)
MAT-WDB-DA-RM-2-0203-1m	2.4/5 GHz, desktop antenna, 2/3 dBi, MIMO 2x2, RP-SMA-type (male), 1 m cable
MAT-WDB-PA-NF-2-0708	2.4/5 GHz, panel antenna, 7/8 dBi, MIMO 2x2, N-type (female)
ANT-WSB5-ANF-12	5 GHz, omni-directional antenna, 12 dBi, N-type (female)
ANT-WSB5-PNF-18	5 GHz, directional panel antenna, 18 dBi, N-type (female)
ANT-WSB-ANF-09	2.4 GHz, omni-directional antenna, 9 dBi, N-type (female)
ANT-WSB-PNF-12	2.4 GHz, directional panel antenna, 12dBi, N-type (female)
ANT-WSB-PNF-18	2.4 GHz, directional panel antenna, 18 dBi, N-type (female)
ANT-WSB-AHRM-05-1.5m	2.4 GHz, omni-directional/dipole antenna, 5 dBi, RP-SMA (male), 1.5 m cable

Wireless Antenna Cables

A-CRF-RFRM-S2-60	SS402 cable, RP-SMA (male) to RP-SMA (female)
A-CRF-RFRM-R4-150	RF magnetic stand, RP-SMA (male) to RP-SMA (female), RG-174/U cable, 1.5 m
A-CRF-RMNM-L1-300	N-type (male) to RP SMA (male), LMR-195 Lite cable, 3 m
A-CRF-RMNM-L1-600	N-type (male) to RP SMA (male), LMR-195 Lite cable, 6 m
A-CRF-RMNM-L1-900	N-type (male) to RP SMA (male), LMR-195 Lite cable, 9 m
CRF-N0117SA-3M	N-type (male) to RP SMA (male), CFD200 cable, 3 m

Surge Arrestors

A-SA-NFNF-01	Surge arrestor, N-type (female) to N-type (female)
A-SA-NMNF-01	Surge arrestor, N-type (female) to N-type (male)

Wireless Adapters

A-ADP-RJ458P-DB9F-ABC01	DB9 female to RJ45 connector for the ABC-01
-------------------------	---

Wireless Terminating Resistors

A-TRM-50-NM	Terminating Resistor, 50 ohm, RP-SMA Male
-------------	---

Wall-Mounting Kits

WK-35-01	Wall-mounting kit, 2 plates, 6 screws, 35 x 44 x 2.5 mm
----------	---

© Moxa Inc. All rights reserved. Updated Nov 18, 2019.

This document and any portion thereof may not be reproduced or used in any manner whatsoever without the express written permission of Moxa Inc. Product specifications subject to change without notice. Visit our website for the most up-to-date product information.

AWK-3131A Series

Industrial IEEE 802.11a/b/g/n wireless AP/bridge/client



Features and Benefits

- IEEE 802.11a/b/g/n AP/bridge/client support
- Easy setup and deployment with AeroMag
- Millisecond-level Client-based Turbo Roaming¹
- Complete redundancy with AeroLink Protection
- Easy network setup with Network Address Translation (NAT)
- Integrated antenna and power isolation
- -40 to 75°C wide operating temperature range (-T models)
- 5 GHz DFS channel support

Certifications



Introduction

The AWK-3131A 3-in-1 industrial wireless AP/bridge/client meets the growing need for faster data transmission speeds by supporting IEEE 802.11n technology with a net data rate of up to 300 Mbps. The AWK-3131A is compliant with industrial standards and approvals covering operating temperature, power input voltage, surge, ESD, and vibration. The two redundant DC power inputs increase the reliability of the power supply, and the AWK-3131A can be powered via PoE to make deployment easier. The AWK-3131A can operate on either the 2.4 or 5 GHz bands and is backwards-compatible with existing 802.11a/b/g deployments to future-proof your wireless investments.

Advanced 802.11n Industrial Wireless Solution

- 802.11a/b/g/n compliant AP/bridge/client for flexible deployment
- Software optimized for long-distance wireless communication with up to 1 km line of sight and external high-gain antenna (available only on 5 GHz)
- Supports 60 clients connected concurrently
- DFS channel support allows a wider range of 5 GHz channel selection to avoid interference from existing wireless infrastructure

Advanced Wireless Technology

- AeroMag supports error-free setup of your industrial applications' fundamental WLAN settings
- Seamless roaming with client-based Turbo Roaming¹ for < 150 ms roaming recovery time between APs (Client Mode)
- Supports AeroLink Protection for creating a redundant wireless link (< 300 ms recovery time) between APs and their clients

Industrial Ruggedness

- Integrated antenna and power isolation designed to provide 500 V insulation protection against external electrical interference
- Hazardous location wireless communication with Class I Div. II and ATEX Zone 2 certifications
- -40 to 75°C wide operating temperature models (-T) provided for smooth wireless communication in harsh environments

Specifications

WLAN Interface

WLAN Standards	802.11a/b/g/n 802.11i Wireless Security
Modulation Type	DSSS OFDM MIMO-OFDM
Frequency Band for US (20 MHz operating channels)	2.412 to 2.462 GHz (11 channels)

1. The Turbo Roaming recovery time indicated herein is an average of test results documented, in optimized conditions, across APs configured with interference-free 20-MHz RF channels, WPA2-PSK security, and default Turbo Roaming parameters. The clients are configured with 3-channel roaming at 100 Kbps traffic load. Other conditions may also impact roaming performance. For more information about Turbo Roaming parameter settings, refer to the product manual.

	5.180 to 5.240 GHz (4 channels) 5.260 to 5.320 GHz (4 channels) ² 5.500 to 5.700 GHz (11 channels) ² 5.745 to 5.825 GHz (5 channels)																								
Frequency Band for EU (20 MHz operating channels)	2.412 to 2.472 GHz (13 channels) 5.180 to 5.240 GHz (4 channels) 5.260 to 5.320 GHz (4 channels) ² 5.500 to 5.700 GHz (11 channels) ²																								
Frequency Band for JP (20 MHz operating channels)	2.412 to 2.484 GHz (14 channels) 5.180 to 5.240 GHz (4 channels) 5.260 to 5.320 GHz (4 channels) ² 5.500 to 5.700 GHz (11 channels) ²																								
Wireless Security	WEP encryption (64-bit and 128-bit) WPA/WPA2-Enterprise (IEEE 802.1X/RADIUS, TKIP, AES) WPA/WPA2-Personal																								
Transmission Rate	802.11b: 1 to 11 Mbps 802.11a/g: 6 to 54 Mbps 802.11n: 6.5 to 300 Mbps																								
Transmitter Power for 802.11a	23±1.5 dBm @ 6 to 24 Mbps 21±1.5 dBm @ 36 Mbps 20±1.5 dBm @ 48 Mbps 18±1.5 dBm @ 54 Mbps																								
Transmitter Power for 802.11n (5 GHz)	23±1.5 dBm @ MCS0/8 20 MHz 18±1.5 dBm @ MCS7/15 20 MHz 23±1.5 dBm @ MCS0/8 40 MHz 17±1.5 dBm @ MCS7/15 40 MHz																								
Transmitter Power for 802.11b	26±1.5 dBm @ 1 Mbps 26±1.5 dBm @ 2 Mbps 26±1.5 dBm @ 5.5 Mbps 25±1.5 dBm @ 11 Mbps																								
Transmitter Power for 802.11g	23±1.5 dBm @ 6 to 24 Mbps 21±1.5 dBm @ 36 Mbps 19±1.5 dBm @ 48 Mbps 18±1.5 dBm @ 54 Mbps																								
Transmitter Power for 802.11n (2.4 GHz)	23±1.5 dBm @ MCS0/8 20 MHz 18±1.5 dBm @ MCS7/15 20 MHz 23±1.5 dBm @ MCS0/8 40 MHz 17±1.5 dBm @ MCS7/15 40 MHz																								
Transmitter Power	<table border="1"> <thead> <tr> <th></th> <th>US</th> <th>EU</th> <th>JP</th> </tr> </thead> <tbody> <tr> <td>2.4 GHz</td> <td>26 dBm</td> <td>18 dBm</td> <td>18 dBm</td> </tr> <tr> <td>5 GHz (UNII-1)</td> <td>23 dBm</td> <td>21 dBm</td> <td>21 dBm</td> </tr> <tr> <td>5 GHz (UNII-2)</td> <td>23 dBm</td> <td>21 dBm</td> <td>21 dBm</td> </tr> <tr> <td>5 GHz (UNII-2e)</td> <td>23 dBm</td> <td>23 dBm</td> <td>23 dBm</td> </tr> <tr> <td>5 GHz (UNII-3)</td> <td>23 dBm</td> <td>–</td> <td>–</td> </tr> </tbody> </table> <p>Note: Based on regional regulations, the maximum transmission power allowed on the UNII bands is restricted in the firmware, as indicated above.</p>		US	EU	JP	2.4 GHz	26 dBm	18 dBm	18 dBm	5 GHz (UNII-1)	23 dBm	21 dBm	21 dBm	5 GHz (UNII-2)	23 dBm	21 dBm	21 dBm	5 GHz (UNII-2e)	23 dBm	23 dBm	23 dBm	5 GHz (UNII-3)	23 dBm	–	–
	US	EU	JP																						
2.4 GHz	26 dBm	18 dBm	18 dBm																						
5 GHz (UNII-1)	23 dBm	21 dBm	21 dBm																						
5 GHz (UNII-2)	23 dBm	21 dBm	21 dBm																						
5 GHz (UNII-2e)	23 dBm	23 dBm	23 dBm																						
5 GHz (UNII-3)	23 dBm	–	–																						
Receiver Sensitivity for 802.11a (measured at 5.680 GHz)	Typ. -90 @ 6 Mbps Typ. -88 @ 9 Mbps Typ. -88 @ 12 Mbps Typ. -85 @ 18 Mbps Typ. -81 @ 24 Mbps																								

2. DFS (Dynamic Frequency Selection) channel support: In AP mode, when a radar signal is detected, the device will automatically switch to another channel. However, according to regulations, after switching channels, a 60-second availability check period is required before starting the service.

	Typ. -78 @ 36 Mbps Typ. -74 @ 48 Mbps Typ. -72 @ 54 Mbps Note ³
Receiver Sensitivity for 802.11n (5 GHz; measured at 5.680 GHz)	Typ. -69 dBm @ MCS7 20 MHz Typ. -71 dBm @ MCS15 20 MHz Typ. -63 dBm @ MCS7 40 MHz Typ. -68 dBm @ MCS15 40 MHz Note ³
Receiver Sensitivity for 802.11b (measured at 2.437 GHz)	Typ. -93 dBm @ 1 Mbps Typ. -93 dBm @ 2 Mbps Typ. -93 dBm @ 5.5 Mbps Typ. -88 dBm @ 11 Mbps
Receiver Sensitivity for 802.11g (measured at 2.437 GHz)	Typ. -88 dBm @ 6 Mbps Typ. -86 dBm @ 9 Mbps Typ. -85 dBm @ 12 Mbps Typ. -85 dBm @ 18 Mbps Typ. -85 dBm @ 24 Mbps Typ. -82 dBm @ 36 Mbps Typ. -78 dBm @ 48 Mbps Typ. -74 dBm @ 54 Mbps
Receiver Sensitivity for 802.11n (2.4 GHz; measured at 2.437 GHz)	Typ. -70 dBm @ MCS7 20 MHz Typ. -69 dBm @ MCS15 20 MHz Typ. -67 dBm @ MCS7 40 MHz Typ. -67 dBm @ MCS15 40 MHz
WLAN Operation Mode	Access point, Client, Client-Router, Master, Slave, Sniffer
Antenna	External, 2/2 dBi, Omni-directional
Antenna Connectors	2 RP-SMA female
Ethernet Interface	
Standards	IEEE 802.3 for 10BaseT IEEE 802.3u for 100BaseT(X) IEEE 802.3ab for 1000BaseT(X) IEEE 802.3af for PoE IEEE 802.1Q for VLAN Tagging IEEE 802.1X for authentication IEEE 802.1D-2004 for Spanning Tree Protocol IEEE 802.1w for Rapid Spanning Tree Protocol
PoE Ports (10/100/1000BaseT(X), RJ45 connector)	1
Ethernet Software Features	
Management	DHCP Server/Client, DNS, HTTP, IPv4, LLDP, Proxy ARP, SMTP, SNMPv1/v2c/v3, Syslog, TCP/IP, Telnet, UDP, VLAN, Wireless Search Utility, MXview, MXconfig
Routing	Port forwarding, Static Route, NAT
Redundancy Protocols	RSTP, STP
Security	HTTPS/SSL, RADIUS, SSH
Time Management	SNTP Client
Firewall	
Filter	ICMP, MAC address, IP protocol, Port-based
Serial Interface	
Console Port	RS-232, 8-pin RJ45

3. Due to a limitation in the receiver sensitivity performance for channels 153 and 161, it is recommended to avoid using these channels in your critical applications.

LED Interface	
LED Indicators	PWR1, PWR2, PoE, FAULT, STATE, SIGNAL, WLAN, LAN
Input/Output Interface	
Digital Inputs	2 Max. input current: 8 mA +13 to +30 V for state 1 +3 to -30 V for state 0
Alarm Contact Channels	Relay output with current carrying capacity of 1 A @ 24 VDC
Buttons	Reset button
Physical Characteristics	
Housing	Metal
IP Rating	IP30
Dimensions	52.7 x 135 x 105 mm (2.08 x 5.32 x 4.13 in)
Weight	860 g (1.9 lb)
Installation	DIN-rail mounting, Wall mounting (with optional kit)
Power Parameters	
Input Current	0.6 A @ 12 VDC, 0.15 A @ 48 VDC
Input Voltage	12 to 48 VDC, Redundant dual inputs, 48 VDC Power-over-Ethernet
Power Connector	1 removable 10-contact terminal block(s)
Power Consumption	7.2 W (max.)
Reverse Polarity Protection	Supported
Environmental Limits	
Operating Temperature	Standard Models: -25 to 60°C (-13 to 140°F) Wide Temp. Models: -40 to 75°C (-40 to 167°F)
Storage Temperature (package included)	-40 to 85°C (-40 to 185°F)
Ambient Relative Humidity	5 to 95% (non-condensing)
Standards and Certifications	
EMC	EN 61000-6-2/-6-4
EMI	CISPR 32, FCC Part 15B Class B
EMS	IEC 61000-4-2 ESD: Contact: 8 kV; Air: 15 kV IEC 61000-4-3 RS: 80 MHz to 1 GHz: 3 V/m IEC 61000-4-4 EFT: Power: 2 kV; Signal: 2 kV IEC 61000-4-5 Surge: Power: 2 kV; Signal: 1 kV IEC 61000-4-6 CS: 3 V IEC 61000-4-8 PFMF
Hazardous Locations	ATEX, Class I Division 2, IECEx
Radio	EN 300 328, EN 301 489-1/17, EN 301 893, FCC ID SLE-WAPN008, ANATEL, MIC, NCC, RCM, SRRC, WPC, KC, RCM
Safety	EN 60950-1, UL 60950-1
Vibration	IEC 60068-2-6

MTBF

Time	570,854 hrs
Standards	Telcordia SR332

Warranty

Warranty Period	5 years
Details	See www.moxa.com/warranty

Package Contents

Device	1 x AWK-3131A Series wireless AP/bridge/client
Installation Kit	2 x cap, plastic, for RJ45 port 1 x cable holder with screw 1 x DIN-rail kit
Antenna	2 x 2.4/5 GHz antenna
Documentation	1 x quick installation guide 1 x warranty card

Dimensions

Unit: mm (inch)

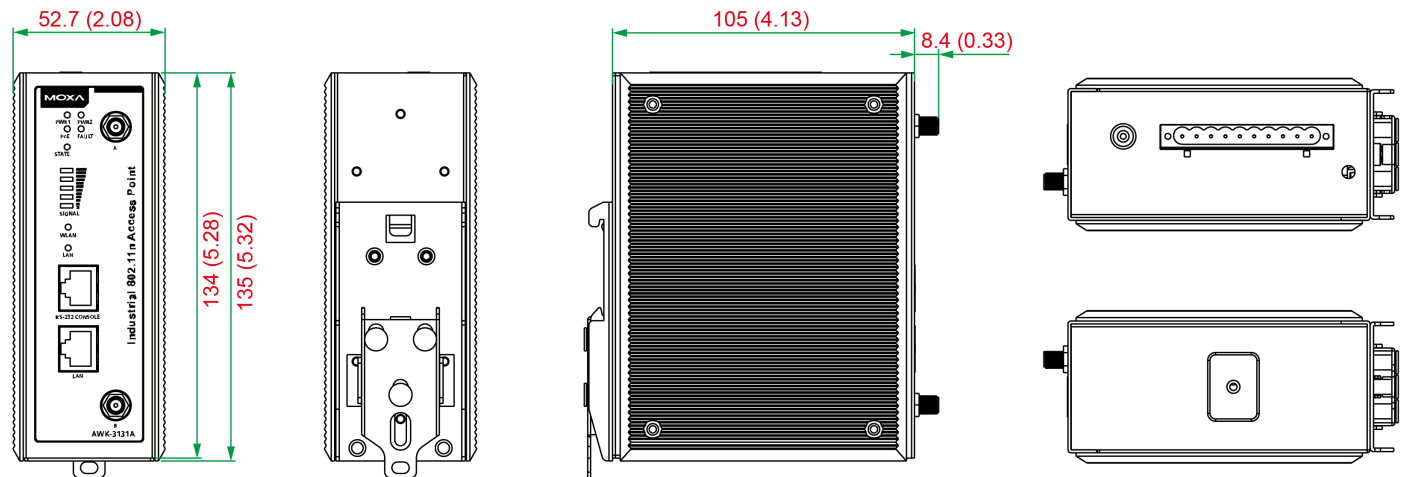

Front View

Rear View

Side View

Top and Bottom Views

Ordering Information

Model Name	Band	Standards	Operating Temp.
AWK-3131A-EU	EU	802.11a/b/g/n	-25 to 60°C
AWK-3131A-EU-T	EU	802.11a/b/g/n	-40 to 75°C
AWK-3131A-JP	JP	802.11a/b/g/n	-25 to 60°C
AWK-3131A-JP-T	JP	802.11a/b/g/n	-40 to 75°C
AWK-3131A-US	US	802.11a/b/g/n	-25 to 60°C
AWK-3131A-US-T	US	802.11a/b/g/n	-40 to 75°C

Accessories (sold separately)

Antennas

ANT-WDB-ANF-0407	2.4/5 GHz, omni-directional antenna, 4/7 dBi, N-type (male)
ANT-WDB-ANF-0609	2.4/5 GHz, omni-directional antenna, 6/9 dBi, N-type (female)
ANT-WDB-ANM-0306	2.4/5 GHz, omni-directional antenna, 3/6 dBi, N-type (male)
ANT-WDB-ANM-0407	2.4/5 GHz, dual-band omni-directional antenna, 4/7 dBi, N-type (male)
ANT-WDB-ANM-0502	2.4/5 GHz, omni-directional antenna, 5/2 dBi, N-type (male)
ANT-WDB-ANM-0609	2.4/5 GHz, omni-directional antenna, 6/9 dBi, N-type (male)
ANT-WDB-ARM-02	2.4/5 GHz, omni-directional rubber duck antenna, 2 dBi, RP-SMA (male)
ANT-WDB-ARM-0202	2.4/5 GHz, panel antenna, 2/2 dBi, RP-SMA (male)
ANT-WDB-PNF-1518	2.4/5 GHz, panel antenna, 15/18 dBi, N-type (female)
MAT-WDB-CA-RM-2-0205	2.4/5 GHz, ceiling antenna, 2/5 dBi, MIMO 2x2, RP-SMA-type (male)
MAT-WDB-DA-RM-2-0203-1m	2.4/5 GHz, desktop antenna, 2/3 dBi, MIMO 2x2, RP-SMA-type (male), 1 m cable
MAT-WDB-PA-NF-2-0708	2.4/5 GHz, panel antenna, 7/8 dBi, MIMO 2x2, N-type (female)
ANT-WSB5-ANF-12	5 GHz, omni-directional antenna, 12 dBi, N-type (female)
ANT-WSB5-PNF-18	5 GHz, directional panel antenna, 18 dBi, N-type (female)
ANT-WSB-ANF-09	2.4 GHz, omni-directional antenna, 9 dBi, N-type (female)
ANT-WSB-PNF-12	2.4 GHz, directional panel antenna, 12dBi, N-type (female)
ANT-WSB-PNF-18	2.4 GHz, directional panel antenna, 18 dBi, N-type (female)
ANT-WSB-AHRM-05-1.5m	2.4 GHz, omni-directional/dipole antenna, 5 dBi, RP-SMA (male), 1.5 m cable

Wireless Antenna Cables

A-CRF-RFRM-R4-150	RF magnetic stand, RP-SMA (male) to RP-SMA (female), RG-174/U cable, 1.5 m
A-CRF-RFRM-S2-60	SS402 cable, RP-SMA (male) to RP-SMA (female)
A-CRF-RMNM-L1-300	N-type (male) to RP SMA (male), LMR-195 Lite cable, 3 m
A-CRF-RMNM-L1-600	N-type (male) to RP SMA (male), LMR-195 Lite cable, 6 m
A-CRF-RMNM-L1-900	N-type (male) to RP SMA (male), LMR-195 Lite cable, 9 m
CRF-N0117SA-3M	N-type (male) to RP SMA (male), CFD200 cable, 3 m

Surge Arrestors

A-SA-NMNF-01	Surge arrester, N-type (female) to N-type (male)
A-SA-NFNF-01	Surge arrester, N-type (female) to N-type (female)

Wireless Terminating Resistors

A-TRM-50-NM	Terminating Resistor, 50 ohm, RP-SMA Male
-------------	---

Wireless Adapters

A-ADP-RJ458P-DB9F-ABC01	DB9 female to RJ45 connector for the ABC-01
-------------------------	---

Wall-Mounting Kits

WK-51-01	Wall-mounting kit, 2 plates, 6 screws, 51.6 x 67 x 2 mm
----------	---

© Moxa Inc. All rights reserved. Updated Nov 18, 2019.

This document and any portion thereof may not be reproduced or used in any manner whatsoever without the express written permission of Moxa Inc. Product specifications subject to change without notice. Visit our website for the most up-to-date product information.

AWK-4131A Series

Outdoor industrial IEEE 802.11a/b/g/n wireless AP/bridge/client



Features and Benefits

- 2x2 MIMO 802.11a/b/g/n AP/bridge/client
- Millisecond-level Client-based Turbo Roaming¹
- Easy setup and deployment with AeroMag
- Wireless redundancy with AeroLink Protection
- Easy network setup with Network Address Translation (NAT)
- Rugged industrial design with integrated antenna and power isolation
- IP68-rated weatherproof housing designed for outdoor applications and -40 to 75°C wide operating temperature range
- Avoid wireless congestion with 5 GHz DFS channel support

Certifications



Introduction

The AWK-4131A IP68 outdoor industrial AP/bridge/client meets the growing need for faster data transmission speeds by supporting 802.11n technology and allowing 2X2 MIMO communication with a net data rate of up to 300 Mbps. The AWK-4131A is compliant with industrial standards and approvals covering operating temperature, power input voltage, surge, ESD, and vibration. The two redundant DC power inputs increase the reliability of the power supply, and the AWK-4131A can be powered via PoE to make deployment easier. The AWK-4131A can operate on either the 2.4 GHz or 5 GHz bands and is backwards-compatible with existing 802.11a/b/g deployments to future-proof your wireless investments.

Advanced 802.11n Industrial Wireless Solution

- 802.11a/b/g/n compliant AP/bridge/client for flexible deployment
- Software-optimized for long-distance wireless communication with up to 1 km line of sight and external high-gain antenna (available only on 5 GHz)
- Supports 60 clients connected concurrently
- DFS channel support allows a wider range of 5 GHz channel selection to avoid interference from existing wireless infrastructure

Advanced Wireless Technology for Mission-critical Applications

- Seamless roaming with client-based Turbo Roaming¹ for < 150 ms roaming recovery time between APs (Client mode)
- AeroMag support for error-free setup of your industrial applications' basic WLAN settings
- Supports AeroLink Protection for creating a redundant wireless link (< 300 ms recovery time) between APs and their clients

Industrial Ruggedness

- Integrated antenna and power isolation designed to provide 500 V insulation protection against external electrical interference
- IP68-rated metal casing for complete ingress protection for any outdoor weather
- -40 to 75°C wide operating temperature models available for smooth wireless communication in harsh environments

Specifications

WLAN Interface

WLAN Standards	802.11a/b/g/n 802.11i Wireless Security
Modulation Type	DSSS OFDM MIMO-OFDM

1. The Turbo Roaming recovery time indicated herein is an average of test results documented, in optimized conditions, across APs configured with interference-free 20-MHz RF channels, WPA2-PSK security, and default Turbo Roaming parameters. The clients are configured with 3-channel roaming at 100 Kbps traffic load. Other conditions may also impact roaming performance. For more information about Turbo Roaming parameter settings, refer to the product manual.

Frequency Band for US (20 MHz operating channels)	2.412 to 2.462 GHz (11 channels) 5.180 to 5.240 GHz (4 channels) 5.260 to 5.320 GHz (4 channels) ² 5.500 to 5.700 GHz (11 channels) ² 5.745 to 5.825 GHz (5 channels)																								
Frequency Band for EU (20 MHz operating channels)	2.412 to 2.472 GHz (13 channels) 5.180 to 5.240 GHz (4 channels) 5.260 to 5.320 GHz (4 channels) ² 5.500 to 5.700 GHz (11 channels) ²																								
Frequency Band for JP (20 MHz operating channels)	2.412 to 2.484 GHz (14 channels) 5.180 to 5.240 GHz (4 channels) 5.260 to 5.240 GHz (4 channels) ² 5.500 to 5.700 GHz (11 channels) ²																								
Wireless Security	WEP encryption (64-bit and 128-bit) WPA/WPA2-Enterprise (IEEE 802.1X/RADIUS, TKIP, AES) WPA/WPA2-Personal																								
Transmission Rate	802.11b: 1 to 11 Mbps 802.11a/g: 6 to 54 Mbps 802.11n: 6.5 to 300 Mbps																								
Transmitter Power for 802.11a	23±1.5 dBm @ 6 to 24 Mbps 21±1.5 dBm @ 36 Mbps 20±1.5 dBm @ 48 Mbps 18±1.5 dBm @ 54 Mbps																								
Transmitter Power for 802.11n (5 GHz)	23±1.5 dBm @ MCS0/8 20 MHz 18±1.5 dBm @ MCS7/15 20 MHz 23±1.5 dBm @ MCS0/8 40 MHz 17±1.5 dBm @ MCS7/15 40 MHz																								
Transmitter Power for 802.11b	26±1.5 dBm @ 1 Mbps 26±1.5 dBm @ 2 Mbps 26±1.5 dBm @ 5.5 Mbps 25±1.5 dBm @ 11 Mbps																								
Transmitter Power for 802.11g	23±1.5 dBm @ 6 to 24 Mbps 21±1.5 dBm @ 36 Mbps 19±1.5 dBm @ 48 Mbps 18±1.5 dBm @ 54 Mbps																								
Transmitter Power for 802.11n (2.4 GHz)	23±1.5 dBm @ MCS0/8 20 MHz 18±1.5 dBm @ MCS7/15 20 MHz 23±1.5 dBm @ MCS0/8 40 MHz 17±1.5 dBm @ MCS7/15 40 MHz																								
Transmitter Power	<table border="1"> <thead> <tr> <th></th> <th>US</th> <th>EU</th> <th>JP</th> </tr> </thead> <tbody> <tr> <td>2.4 GHz</td> <td>26 dBm</td> <td>18 dBm</td> <td>18 dBm</td> </tr> <tr> <td>5 GHz (UNII-1)</td> <td>23 dBm</td> <td>21 dBm</td> <td>21 dBm</td> </tr> <tr> <td>5 GHz (UNII-2)</td> <td>23 dBm</td> <td>21 dBm</td> <td>21 dBm</td> </tr> <tr> <td>5 GHz (UNII-2e)</td> <td>23 dBm</td> <td>23 dBm</td> <td>23 dBm</td> </tr> <tr> <td>5 GHz (UNII-3)</td> <td>23 dBm</td> <td>–</td> <td>–</td> </tr> </tbody> </table> <p>Note: Based on regional regulations, the maximum transmission power allowed on the UNII bands is restricted in the firmware, as indicated above.</p>		US	EU	JP	2.4 GHz	26 dBm	18 dBm	18 dBm	5 GHz (UNII-1)	23 dBm	21 dBm	21 dBm	5 GHz (UNII-2)	23 dBm	21 dBm	21 dBm	5 GHz (UNII-2e)	23 dBm	23 dBm	23 dBm	5 GHz (UNII-3)	23 dBm	–	–
	US	EU	JP																						
2.4 GHz	26 dBm	18 dBm	18 dBm																						
5 GHz (UNII-1)	23 dBm	21 dBm	21 dBm																						
5 GHz (UNII-2)	23 dBm	21 dBm	21 dBm																						
5 GHz (UNII-2e)	23 dBm	23 dBm	23 dBm																						
5 GHz (UNII-3)	23 dBm	–	–																						
Receiver Sensitivity for 802.11a (measured at 5.680 GHz)	Typ. -90 @ 6 Mbps Typ. -88 @ 9 Mbps Typ. -88 @ 12 Mbps Typ. -85 @ 18 Mbps																								

2. DFS (Dynamic Frequency Selection) channel support: In AP mode, when a radar signal is detected, the device will automatically switch to another channel. However, according to regulations, after switching channels, a 60-second availability check period is required before starting the service.

	Typ. -81 @ 24 Mbps Typ. -78 @ 36 Mbps Typ. -74 @ 48 Mbps Typ. -72 @ 54 Mbps Note ³
Receiver Sensitivity for 802.11n (5 GHz; measured at 5.680 GHz)	Typ. -69 dBm @ MCS7 20 MHz Typ. -71 dBm @ MCS15 20 MHz Typ. -63 dBm @ MCS7 40 MHz Typ. -68 dBm @ MCS15 40 MHz Note ³
Receiver Sensitivity for 802.11b (measured at 2.437 GHz)	Typ. -93 dBm @ 1 Mbps Typ. -93 dBm @ 2 Mbps Typ. -93 dBm @ 5.5 Mbps Typ. -88 dBm @ 11 Mbps
Receiver Sensitivity for 802.11g (measured at 2.437 GHz)	Typ. -88 dBm @ 6 Mbps Typ. -86 dBm @ 9 Mbps Typ. -85 dBm @ 12 Mbps Typ. -85 dBm @ 18 Mbps Typ. -85 dBm @ 24 Mbps Typ. -82 dBm @ 36 Mbps Typ. -78 dBm @ 48 Mbps Typ. -74 dBm @ 54 Mbps
Receiver Sensitivity for 802.11n (2.4 GHz; measured at 2.437 GHz)	Typ. -70 dBm @ MCS7 20 MHz Typ. -69 dBm @ MCS15 20 MHz Typ. -67 dBm @ MCS7 40 MHz Typ. -67 dBm @ MCS15 40 MHz
WLAN Operation Mode	Access point, Client, Client-Router, Master, Slave, Sniffer
Antenna	External, 3/6 dBi, Omni-directional
WLAN Antenna Connector	2 N-type female
Ethernet Interface	
Standards	IEEE 802.3 for 10BaseT IEEE 802.3u for 100BaseT(X) IEEE 802.3ab for 1000BaseT(X) IEEE 802.3af for PoE IEEE 802.1D-2004 for Spanning Tree Protocol IEEE 802.1w for Rapid Spanning Tree Protocol IEEE 802.1Q for VLAN Tagging
PoE Ports (10/100/1000BaseT(X), RJ45 connector)	1
Ethernet Software Features	
Management	DHCP Server/Client, DNS, HTTP, IPv4, LLDP, Proxy ARP, SMTP, SNMPv1/v2c/v3, Syslog, TCP/IP, Telnet, UDP, VLAN, Wireless Search Utility, MXview, MXconfig
Routing	Static Route, NAT, Port forwarding
Redundancy Protocols	RSTP, STP
Security	HTTPS/SSL, RADIUS, SSH
Time Management	SNTP Client
Firewall	
Filter	ICMP, MAC address, IP protocol, Port-based
Serial Interface	
Console Port	RS-232, 8-pin RJ45

3. Due to a limitation in the receiver sensitivity performance for channels 153 and 161, it is recommended to avoid using these channels in your critical applications.

LED Interface	
LED Indicators	PWR, FAULT, STATE, WLAN, LAN
Input/Output Interface	
Alarm Contact Channels	Relay output with current carrying capacity of 1 A @ 24 VDC
Buttons	Reset button
Digital Inputs	+13 to +30 V for state 1 +3 to -30 V for state 0 Max. input current: 8 mA
Physical Characteristics	
Housing	Metal
IP Rating	IP68
Dimensions	224 x 147.7 x 66.5 mm (8.82 x 5.82 x 2.62 in)
Weight	1,400 g (3.09 lb)
Installation	Wall mounting (standard), DIN-rail mounting (optional), Pole mounting (optional)
Power Parameters	
Input Current	0.64 A @ 12 VDC, 0.16 A @ 48 VDC
Input Voltage	12 to 48 VDC, Redundant dual inputs, 48 VDC Power-over-Ethernet
Power Connector	M12 A-coded 5-pin male connector
Power Consumption	7.68 W (max.)
Reverse Polarity Protection	Supported
Environmental Limits	
Operating Temperature	-40 to 75°C (-40 to 167°F)
Storage Temperature (package included)	-40 to 85°C (-40 to 185°F)
Ambient Relative Humidity	5 to 95% (non-condensing)
Standards and Certifications	
EMC	EN 61000-6-2/-6-4
EMI	CISPR 32, FCC Part 15B Class B
EMS	IEC 61000-4-2 ESD: Contact: 8 kV; Air: 15 kV IEC 61000-4-3 RS: 80 MHz to 1 GHz: 10 V/m IEC 61000-4-4 EFT: Power: 2 kV; Signal: 1 kV IEC 61000-4-5 Surge: Power: 2 kV; Signal: 2 kV IEC 61000-4-6 CS: 10 V IEC 61000-4-8 PFMF
Radio	EN 300 328, EN 301 489-1/17, EN 301 893, FCC ID SLE-WAPN008, ANATEL, MIC, NCC, RCM, SRRC, WPC, KC
Safety	EN 60950-1, UL 60950-1
Vibration	IEC 60068-2-6
MTBF	
Time	440,764 hrs
Standards	Telcordia SR332

Warranty

Warranty Period	5 years
Details	See www.moxa.com/warranty

Package Contents

Device	1 x AWK-4131A Series wireless AP/bridge/client
Installation Kit	1 x cap, female, metal, for M12 port 1 x cap, metal, for RJ45 port 1 x field-installable power plug 1 x field-installable RJ45 plug 1 x stick, transparent plastic, for field-installable plug 2 x wall-mounting kit
Antenna	2 x 2.4/5 GHz antenna
Documentation	1 x quick installation guide 1 x warranty card

Dimensions

Unit: mm (inch)

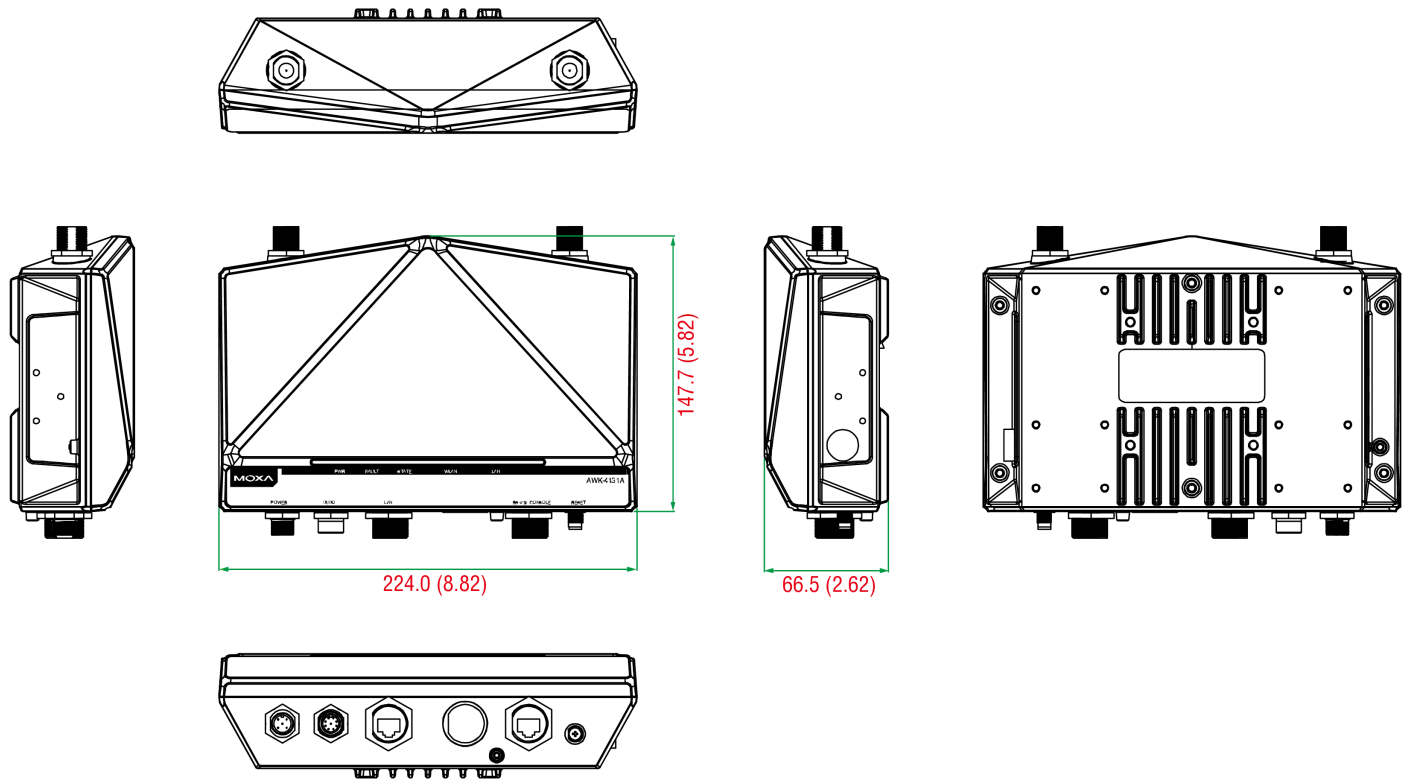

Side View

Front, Top, and Rear Views

Side View

Bottom View

Ordering Information

Model Name	Band	Standards	Operating Temp.
AWK-4131A-EU-T	EU	802.11a/b/g/n	-40 to 75°C
AWK-4131A-JP-T	JP	802.11a/b/g/n	-40 to 75°C
AWK-4131A-US-T	US	802.11a/b/g/n	-40 to 75°C

Accessories (sold separately)

Antennas

ANT-WDB-ANF-0407	2.4/5 GHz, omni-directional antenna, 4/7 dBi, N-type (male)
ANT-WDB-ANF-0609	2.4/5 GHz, omni-directional antenna, 6/9 dBi, N-type (female)
ANT-WDB-ANM-0306	2.4/5 GHz, omni-directional antenna, 3/6 dBi, N-type (male)
ANT-WDB-ANM-0407	2.4/5 GHz, dual-band omni-directional antenna, 4/7 dBi, N-type (male)
ANT-WDB-ANM-0502	2.4/5 GHz, omni-directional antenna, 5/2 dBi, N-type (male)
ANT-WDB-ANM-0609	2.4/5 GHz, omni-directional antenna, 6/9 dBi, N-type (male)
ANT-WDB-ARM-02	2.4/5 GHz, omni-directional rubber duck antenna, 2 dBi, RP-SMA (male)
ANT-WDB-ARM-0202	2.4/5 GHz, panel antenna, 2/2 dBi, RP-SMA (male)
ANT-WDB-PNF-1518	2.4/5 GHz, panel antenna, 15/18 dBi, N-type (female)
MAT-WDB-CA-RM-2-0205	2.4/5 GHz, ceiling antenna, 2/5 dBi, MIMO 2x2, RP-SMA-type (male)
MAT-WDB-DA-RM-2-0203-1m	2.4/5 GHz, desktop antenna, 2/3 dBi, MIMO 2x2, RP-SMA-type (male), 1 m cable
MAT-WDB-PA-NF-2-0708	2.4/5 GHz, panel antenna, 7/8 dBi, MIMO 2x2, N-type (female)
ANT-WSB5-ANF-12	5 GHz, omni-directional antenna, 12 dBi, N-type (female)
ANT-WSB5-PNF-18	5 GHz, directional panel antenna, 18 dBi, N-type (female)
ANT-WSB-ANF-09	2.4 GHz, omni-directional antenna, 9 dBi, N-type (female)
ANT-WSB-PNF-12	2.4 GHz, directional panel antenna, 12dBi, N-type (female)
ANT-WSB-PNF-18	2.4 GHz, directional panel antenna, 18 dBi, N-type (female)
ANT-WSB-AHRM-05-1.5m	2.4 GHz, omni-directional/dipole antenna, 5 dBi, RP-SMA (male), 1.5 m cable

Wireless Antenna Cables

A-CRF-NMNM-LL4-300	N-type (male) to N-type (male), LMR-400 Lite cable, 3 m
A-CRF-NMNM-LL4-600	N-type (male) to N-type (male), LMR-400 Lite cable, 6 m
A-CRF-NMNM-LL4-900	N-type (male) to N-type (male), LMR-400 Lite cable, 9 m
CRF-N0429N-3M	N-type (male) to N-type (male), CFD400 cable, 3 m

Wireless AP Connector Cables

M12A-8PFF-IP68	Field-installation A-coded M12 screw-in 8-pin connector, female connector female PIN
M12A-8PMM-IP68	Field-installation A-coded screw-in Gigabit Ethernet connector, 8-pin male M12 connector, IP68-rated
A-PLG-WPRJ	Field-installation RJ-type plug

Wireless Connector Caps

A-CAP-N-M	Metal cap to cover N-type connector
A-CAP-WPRJ45-MC	Metal cap with chain for RJ45 connector

Surge Arrestors

A-SA-NMNF-01	Surge arrester, N-type (female) to N-type (male)
A-SA-NFNF-01	Surge arrester, N-type (female) to N-type (female)

Wireless Adapters

A-ADP-RJ458P-DB9F-ABC01	DB9 female to RJ45 connector for the ABC-01
-------------------------	---

Wireless Terminating Resistors

A-TRM-50-NM	Terminating Resistor, 50 ohm, RP-SMA Male
-------------	---

Wall-Mounting Kits

WK-51-01

Wall-mounting kit, 2 plates, 6 screws, 51.6 x 67 x 2 mm

Wireless AP Mounting Kits

WK-55

Wall-mounting kit, 55 x 34.5 x 2.5 mm

© Moxa Inc. All rights reserved. Updated Nov 18, 2019.

This document and any portion thereof may not be reproduced or used in any manner whatsoever without the express written permission of Moxa Inc. Product specifications subject to change without notice. Visit our website for the most up-to-date product information.