

NAT-108 Series

8-port industrial Network Address Translation (NAT) devices



Features and Benefits

- User-friendly NAT functionality simplifies network integration
- NAT IP Twins Mapping remaps duplicate LAN IP addresses for conflict-free communication
- Hands-free network access control through automatic whitelisting of locally connected devices
- Ultra-compact size and robust industrial design suitable for cabinet installation
- Integrated security features to ensure device and network safety
- Supports Secure Boot for checking system integrity
- -40 to 75°C operating temperature range (-T model)

Certifications



Introduction

The NAT-108 Series is an industrial NAT device that is designed to simplify the IP configuration of machines in existing network infrastructure in factory automation environments. The NAT-108 Series supports comprehensive NAT functionality, including market-leading IP Twins Mapping for 1-to-1 NAT, to resolve LAN IP conflicts between factory devices. These devices allow your machines to adapt to specific network scenarios without complicated, costly, and time-consuming configurations, while also protecting the internal network from unauthorized access by outside hosts.

Market-leading IP Twins Mapping

The NAT-108 Series supports the market-leading IP Twins Mapping feature for NAT. By manually configuring duplicate LAN IP addresses, the system automatically remaps them to unique addresses, effectively eliminating communication conflicts. This feature ensures that critical industrial devices such as PLCs, communicate seamlessly, significantly enhancing network efficiency and reliability even in the most challenging industrial environments.

Quick and User-friendly Access Control

The NAT-108 Series' Device Lockdown feature automatically learns or lets users manually add the IP and MAC address of locally connected devices and binds them to the access list. This feature not only helps you manage access control but also makes device replacements much more efficient.

Industrial-grade and Ultra-compact Design

The NAT-108 Series' rugged hardware makes these NAT devices ideal for deployment in harsh industrial environments, featuring wide-temperature models that are built to operate reliably in hazardous conditions and extreme temperatures of -40 up to 75°C. Moreover, the ultra-compact size allows the NAT-108 Series to be easily installed into cabinets.

Specifications

Input/Output Interface

Buttons	Reset button
Ethernet Interface	
10/100BaseT(X) Ports (RJ45 connector)	8
Standards	IEEE 802.3 for 10BaseT IEEE 802.3u for 100BaseT(X) IEEE 802.3x for flow control

Ethernet Software Features

Management	Web Console (HTTP/HTTPS) LLDP Telnet TFTP HTTPS SSH Back Pressure Flow Control SNMPv1/v2c/v3 DHCP Server/Client
Security	Secure Boot Trust access control
Time Management	NTP Server/Client SNTP
Unicast Routing	Static Route
Routing	Throughput: 15K packets per second (max. 100 Mbps)
Routing Table	Max. 300 routing rules
Concurrent Connections	Max. 30K
Connections Per Second	Max. 4.5K
LED Interface	
LED Indicators	POWER, STATE, LEARNING, LOCKDOWN
Firewall	
Filter	IP address MAC address Ports
Port-based Auto Learning Lock	MAC address IP address
Throughput	Max. 15K packets per second (max. 100 Mbps)
NAT	
Features	1-to-1 N-to-1 Port forwarding NAT loopback IP Twins Mapping
Throughput	Max. 15K packets per second (max. 100 Mbps)
Real-Time Firewall / VPN Event Log	
Event Type	Policy enforcement
Media	Local storage Syslog server
Serial Interface	
Console Port	RS-232 (TxD, RxD, GND), 3-pin (115200, n, 8, 1)
Connector	USB Type-C
Power Parameters	
Connection	Removable terminal block
Operating Voltage	9.6 to 60 VDC

Input Voltage	12/24/48 VDC
Input Current	0.35 A @ 12 VDC 0.18 A @ 24 VDC 0.09 A @ 48 VDC
Reverse Polarity Protection	Supported

Physical Characteristics

Housing	Metal
Dimensions	36 x 90 x 73 mm (1.42 x 3.54 x 2.87 in)
Weight	330 g (0.73 lb)
Installation	DIN-rail mounting Wall mounting (with optional kit)

Environmental Limits

Operating Temperature	Standard models: -10 to 60°C (14 to 140°F) Wide temp. models: -40 to 75°C (-40 to 167°F)
Storage Temperature (package included)	-40 to 85°C (-40 to 185°F)
Ambient Relative Humidity	5 to 95% (non-condensing)

Standards and Certifications

Safety	UL 62368-1
EMC	EN 55032/35
EMI	CISPR 32, FCC Part 15B Class A
EMS	IEC 61000-4-2 ESD: Contact: 6 kV; Air: 8 kV IEC 61000-4-3 RS: 80 MHz to 1 GHz: 10 V/m IEC 61000-4-4 EFT: Power: 2 kV; Signal: 2 kV IEC 61000-4-5 Surge: Power: 2 kV; Signal: 2 kV IEC 61000-4-6 CS: 10 V IEC 61000-4-8 PFMF
Shock	IEC 60068-2-27
Freefall	ISTA 1A
Vibration	IEC 60068-2-6 IEC 60068-2-64

MTBF

Time	5,640,140 hrs
Standards	Telcordia (Bellcore), GB

Warranty

Warranty Period	5 years
Details	See www.moxa.com/warranty

Package Contents

Device	1 x NAT-108 Series NAT device
Cable	1 x DB9 female to USB Type-C
Documentation	1 x quick installation guide 1 x warranty card

Dimensions

DIN-rail Mount

Unit: mm (inch)

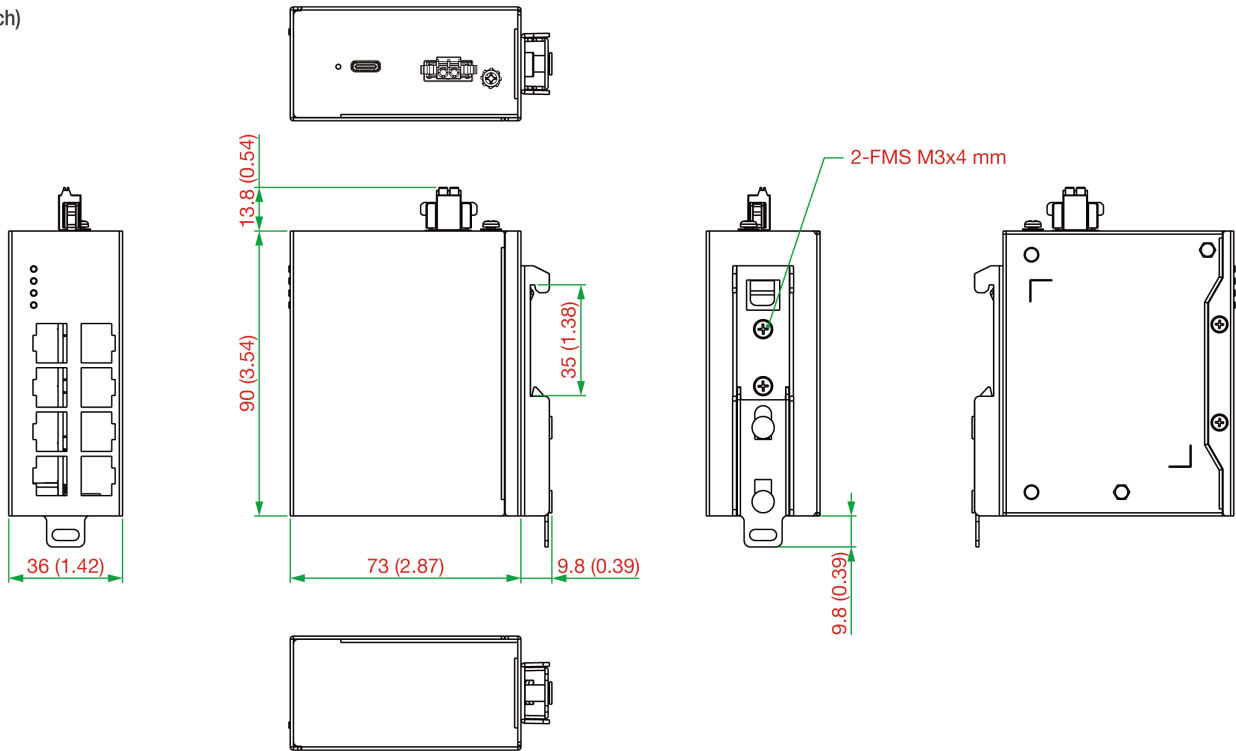

Wall Mount

Unit: mm (inch)

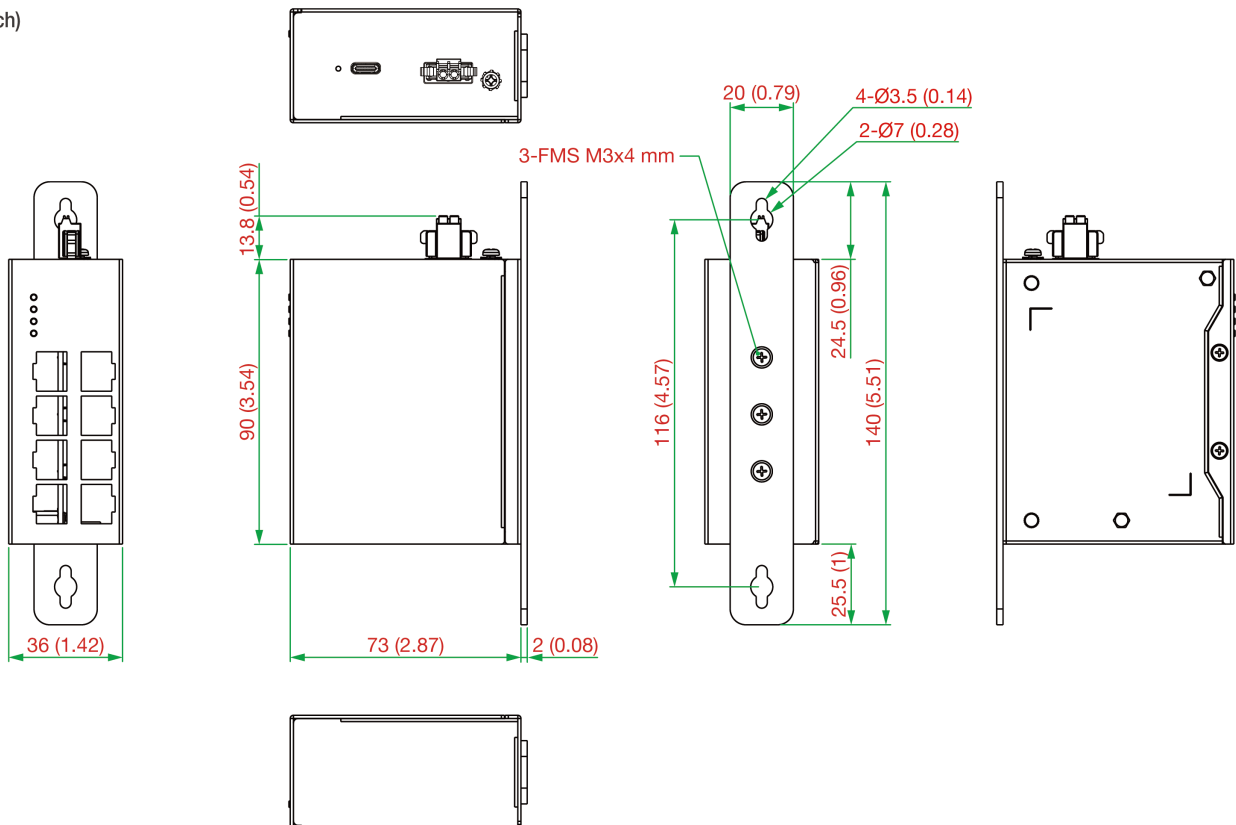

Ordering Information

Model Name	10/100BaseT(X) Ports (RJ45 Connector)	NAT	Operating Temp.
NAT-108	8	✓	-10 to 60°C
NAT-108-T	8	✓	-40 to 75°C

Accessories (sold separately)

Wall-Mounting Kits

WK-20-02	Wall-mounting kit, 3 screws, 20 x 140 x 2 mm
----------	--

© Moxa Inc. All rights reserved. Updated Apr 09, 2025.

This document and any portion thereof may not be reproduced or used in any manner whatsoever without the express written permission of Moxa Inc. Product specifications subject to change without notice. Visit our website for the most up-to-date product information.